



CITY OF NORTH RIDGEVILLE

UTILITIES DEPARTMENT



SECOND WATER METER (Deduct Meter)

PROCEDURES:

1. A testable Backflow Prevention Assembly must be installed for Underground Lawn Irrigation Systems. Hose bibs require a Vacuum Breaker Backflow Prevention Assembly. The Building Department will conduct a Meter Set-up Inspection and Lawn Irrigation System Inspection; the backflow device on lawn sprinkler systems must be tested upon installation and report provided to the City Engineer or to the Inspector before final approval is given.
2. If desired all exterior hose bibs may be on the deduct meter. Plumbing must be changed/set-up so that all outside faucets are on the deduct meter line. This means after your first water meter, you would T-off or Y-off the main entrance line and install your second meter and backflow prevention device on the line that services your outside faucets or underground lawn irrigation system. Every house is a little different on plumbing set-up.
3. A permit is required for inspection of your changes and set-up for second meter.
The second meter is to be set-up the same as for the first meter only after the first meter on your line and connected to exterior faucets. (See the attached drawings) **Permit** should be obtained from the Building Department. See fees listed on Residential Building Permit Fees page (website or handout). After permit is issued and plumbing changes are made, the homeowner or plumber must call the Utilities Department (**353-0841**) for an appointment to have the water meter installed.

With the second (deduct) meter, residents are charged for water usage only on the second water meter and will receive a credit on their bill for sewer charges that are billed on the first meter.

Example: monthly usage on first meter is 1400 cubic feet (or 14 usage) and the monthly usage on the second meter is 500 cubic feet (or 5 usage).

<i>The bill would be:</i>	Water	\$49.44 (14 use)
	Sewer	\$56.56 (14 use)
	Deduct Meter -	\$19.55 (5 use)
	Total	\$86.45

In effect, the customer would be billed a 14 usage for water and only a 9 usage for sewer since a 5 usage was on the second water meter that registers exterior water use.

The second water meters are for outside usage only, such as car washing, filling swimming pools, watering lawns and gardens, etc.

Contact the Utilities Department for the cost of the water meter. This can be paid at the Utilities Department or the charge for the meter can be billed on your next monthly utility statement.



THE CITY OF NORTH RIDGEVILLE
 7307 Avon Belden Road, North Ridgeville, Ohio 44039
 Telephone: (440) 353-0822 Fax: (440) 353-0823



Building Department

RESIDENTIAL PLAN APPROVAL APPLICATION

CONTRACTOR: _____
 NAME DATE

ADDRESS PHONE

PROPERTY OWNER: _____
 NAME

ADDRESS CITY ZIP PHONE

CONSTRUCTION SITE ADDRESS: _____

(CHECK ALL ACTIVITIES PERTAINING TO THIS APPLICATION)

NEW CONSTRUCTION: Single Family Multi-Family # of Units _____

Square Feet: Finished Basement: _____ 1st Fl.: _____ 2nd Fl.: _____ Total: _____

Garage: Attached Detached Storage Building Size: W _____ x D _____ Square Feet: _____

Sub Lot # _____ Permanent Parcel # _____ Water Permit # _____

Zoning District : _____ Subdivision: _____ Model / Plan Name: _____

YARD REQUIREMENTS: Width at R.O.W. : _____ Flood Plain Zone: _____

ADDITION / ALTERATION: Year Dwelling Built: _____ Addition / Alteration Square Footage: _____

Dwelling Addition Garage Addition Storage Bldg. Addition Kitchen Remodel Basement Remodel

GENERAL PERMITS:

- Re-Siding Re-Roofing Fire Damage Repair Second water meter
- Demo Above Ground Pool In Ground Pool Lawn Sprinkler
- Gazebo Other : _____
- Fence Style: _____ Size: _____
- Deck Size: _____ Square Feet: _____

GENERAL PERMIT FEES:

PERMIT	\$ _____
STATE 1%	\$ _____
ADMIN.	\$ _____
TOTAL	\$ _____

HVAC Heat: New Replacement A/C: New Replacement Fireplace: New Replacement

Condensing Unit Location: Rear yard Left side yard Right side yard

Furnace Capacity: _____ BTU's Water Heater Capacity: _____ BTU's

Furnace Fuel Type Natural Gas L.P. Gas Electric Other _____

Water Heater Fuel Type Natural Gas L.P. Gas Electric Other _____

Air Conditioner Capacity _____ Tons Ductwork Type: Sheet metal Duct board

Gas Meter Location Front yard Rear yard Left side yard Right side yard

Water Meter Location Front Rear Left side Right side

The following information must be clearly identified on the Construction drawings: **Furnace location, water heater location, vent termination for dryer, furnace & water heater, water meter location (if slab construction)**

Indicate 2009 IECC compliance method: _____



THE CITY OF NORTH RIDGEVILLE
7307 Avon Belden Road, North Ridgeville, Ohio 44039
Telephone: (440) 353-0822 Fax: (440) 353-0823



Building Department

PLUMBING

New Alteration Service Line

Indicate fixture count below:

Water Closet _____ Floor Drain _____ Bidet _____ Backflow Device _____
 Lavatory Sink _____ Laundry Tub _____ Water Heater _____ Clothes Washer _____
 Bath Tub _____ Dishwasher _____ Sewage Grinder _____ Sump Pump _____
 Hot Tub _____ Shower _____ Garbage Disposal _____ Other _____

Building Main Drain size: _____ inches Building Water Service size: _____ inches

Water Distribution System Copper PVC / plastic

ELECTRICAL

New Alteration / Addition Service Change Service Entrance

Service Amps _____

Indicate load wattages & amperages for each item applicable below:

Range _____ watts Cook top _____ watts Oven _____ watts
 Electric Water Heater _____ watts Electric Clothes Dryer _____ watts Gas Clothes Dryer _____ watts
 Dishwasher _____ watts Disposal _____ watts Sump Pump _____ watts
 Sewage Ejector _____ watts Water Pump _____ watts _____ watts
 Air Conditioner _____ volts _____ amps Furnace _____ volts _____ amps
 Electric Space Heater _____ volts _____ amps Heat Pump _____ volts _____ amps

TRADE	NAME OF CONTRACTOR	REGISTERED	
Masonry	_____	<input type="checkbox"/> Yes	<input type="checkbox"/> No
Carpentry	_____	<input type="checkbox"/> Yes	<input type="checkbox"/> No
Plumbing	_____	<input type="checkbox"/> Yes	<input type="checkbox"/> No
Electrical	_____	<input type="checkbox"/> Yes	<input type="checkbox"/> No
HVAC	_____	<input type="checkbox"/> Yes	<input type="checkbox"/> No
Decorating	_____	<input type="checkbox"/> Yes	<input type="checkbox"/> No
Floor Covering	_____	<input type="checkbox"/> Yes	<input type="checkbox"/> No
Drywall	_____	<input type="checkbox"/> Yes	<input type="checkbox"/> No
Excavator	_____	<input type="checkbox"/> Yes	<input type="checkbox"/> No
Pool Erector	_____	<input type="checkbox"/> Yes	<input type="checkbox"/> No
Landscaper	_____	<input type="checkbox"/> Yes	<input type="checkbox"/> No
Other	_____	<input type="checkbox"/> Yes	<input type="checkbox"/> No

NOTE: All contractors submitted regarding this permit, must be registered and approved by the Building Dept. for the current year.

Cost of Construction: _____ Applicant's Signature _____

Property Owner's Signature _____

Sidewalk Ordinance received date: _____ Applicant's Signature _____

Date: _____ Approved: _____

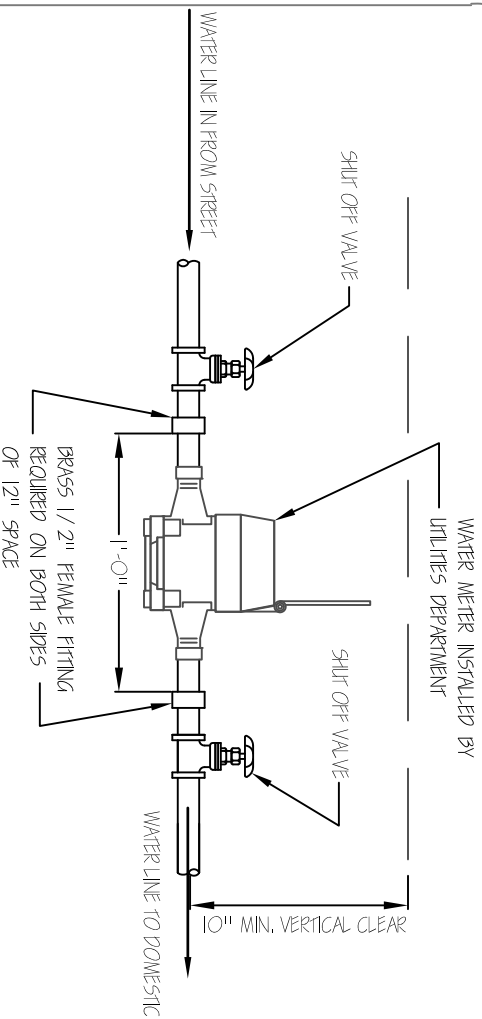

NOTE:
 ALL WATER METERS TO BE INSTALLED HORIZONTALLY;
 4" MINIMUM HORIZONTAL CLEARANCE FROM CENTERLINE OF PIPE TO WALL OR OBJECT
 SECOND METER TO BE INSTALLED DOWNSTREAM (AFTER) MAIN HOUSE METER

HOUSE WATER METER

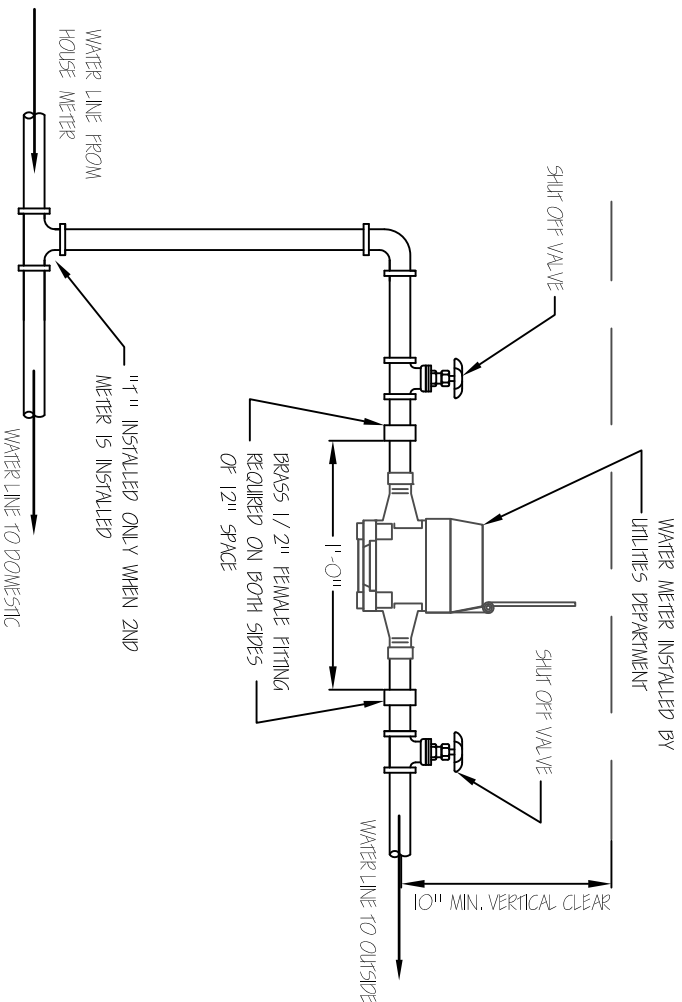

NOTE: final configuration of piping and location of meter is determined in the field depending on available space

SECOND (DEDUCT) WATER METER

TYPICAL WATER METER INSTALLATION

DRAWING IS NOT TO SCALE

CITY of
 NORTH
 RIDGEVILLE

DATE:
 OCT. 2014

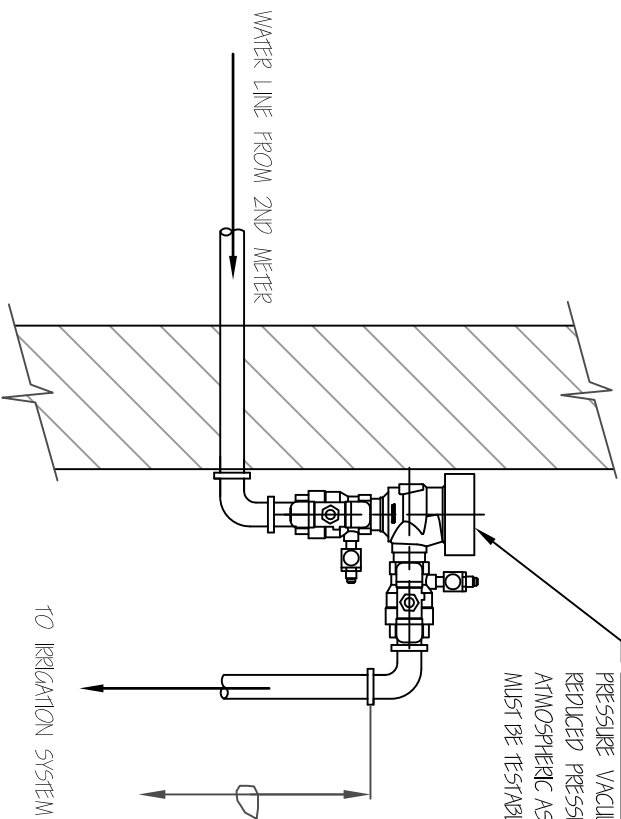

BACK FLOW PREVENTER:
 PRESSURE VACUUM BREAKER ASSE 1020
 REDUCED PRESSURE PRINCIPLE ASSE 1015
 ATMOSPHERIC ASSE 1001
 MUST BE TESTABLE

12" MIN. CLEARANCE ABOVE
 HIGHEST POINT OF DOWNSTREAM
 PIPING WITH PVB TYPE
 TO IRRIGATION SYSTEM

NOTE:
 BACK FLOW DEVICE MUST BE TESTED
 UPON INSTALLATION & REPORT PROVIDED
 TO CITY

LAWN IRRIGATION SYSTEM

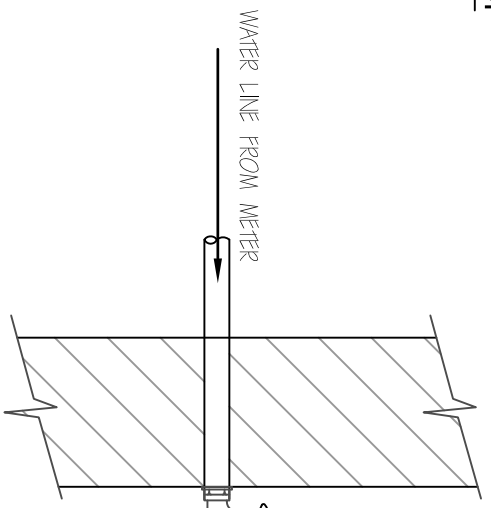

HOSE CONNECTION VACUUM BREAKER
 ASSE 1052, ASSE 1011, ASSE 1019,
 ASSE 1035
 MAY BE EXTERNAL, SCREW ON TYPE or
 MANUFACTURED AS PART OF THE HOSE
 BIBB UNIT

**LAWN IRRIGATION &
 HOSE BIBB BACKFLOW**

DRAWING IS NOT TO SCALE

**CITY of
 NORTH
 RIDGEVILLE**

DATE:
 Sept. 2010

EXTERIOR HOSE BIBB